



## FREE VIBRATION METHOD FOR TECHNICAL CONDITION ASSESSMENT OF AUTOMOTIVE SHOCK ABSORBERS

Łukasz KONIECZNY<sup>1</sup>, Jan WARCZEK<sup>2</sup>, Jakub MŁYNCZAK<sup>3</sup>, Maciej ZAWISZA<sup>4</sup>

<sup>1</sup>The Silesian University of Technology, Faculty of Transport, Poland, email: [lukasz.konieczny@polsl.pl](mailto:lukasz.konieczny@polsl.pl)

<sup>2</sup>The Silesian University of Technology, Faculty of Transport, Poland, email: [jan.warczek@polsl.pl](mailto:jan.warczek@polsl.pl)

<sup>3</sup>The Silesian University of Technology, Faculty of Transport, Poland, email: [jakub.mlynczak@polsl.pl](mailto:jakub.mlynczak@polsl.pl)

<sup>4</sup>Warsaw University of Technology, Faculty of Automotive and Construction Machinery Engineering, Poland, email: [maciej.zawisza@simr.pw.edu.pl](mailto:maciej.zawisza@simr.pw.edu.pl)

### Abstract

The article provides a discussion on oscillatory methods used for technical condition assessment of shock absorbers in automotive vehicles, focusing primarily on free vibration methods. It comments on results of simulation studies of a simple two-mass model conducted by application of a pulse input function. Results of experimental tests have also been provided in the paper. The foregoing tests consisted in recording of accelerations of the body of an automotive vehicle equipped with a shock absorber enabling simulation of shock absorbing liquid leakage. The follow-up analyses were conducted to establish the decrement of damping as well as the damping coefficient.

Keywords: free vibration method, shock absorber, damping characteristics

### METODA DRGAŃ SWOBODNYCH W OCENIE STANU TECHNICZNEGO AMORTYZATORÓW POJAZDÓW SAMOCHODOWYCH

#### Streszczenie

W artykule opisano metody drganiowe stosowane w ocenie stanu technicznego zawieszenia pojazdu samochodowego ze szczególnym uwzględnieniem metody drgań swobodnych. Przedstawiono wyniki badań symulacyjnych dla prostego modelu dwumasowego przy wykorzystaniu wymuszenia impulsowego. Zaprezentowano również wyniki badań eksperymentalnych. Badania te polegały na rejestracji przyśpieszeń drgań nadwozia pojazdu samochodowego wyposażonego w amortyzator umożliwiającą zasymulowanie wycieku płynu amortyzatorowego. W ramach analiz wyznaczono dekrement tłumienia oraz współczynnik tłumienia.

Słowa kluczowe: metoda drgań swobodnych, amortyzatory, charakterystyka tłumienia

## 1. INTRODUCTION

Technical condition of shock absorbers installed in a vehicle may be assessed by way of a vibration test using one of the following methods:

- forced vibration method,
- free vibration method.

The free vibration method is a simple and low-cost method of shock absorber testing. It is based on analysis of vibrations of a passenger car after it has been pulse excited to free vibrations. The most popular method (no longer used in vehicle inspection stations) used to be the falling weight method (see the testing station by KONI at Fig. 1). According to this method, the test is conducted using a drive-on station where a moving support bracket is coupled with a system of levers with a mechanical or pneumatic lifting mechanism. After the lifting operation is complete, the mechanism is unlocked by the control system causing the bracket to fall along with the vehicle. Both the sprung mass

and the unsprung mass are excited to vibrate by the falling wheel which hits a pressure plate.

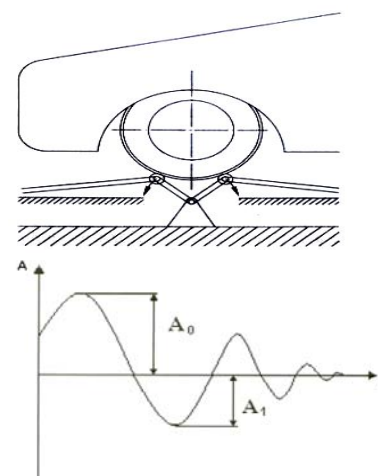

Fig. 1. Schematic diagram of a shock absorber testing station based on the free vibration method and results of recording by application of the falling car weight method [6]

Another popular solution was releasing a compressed car body, a method which consisted in applying a short and strong thrust with the body on the shock absorber subject to testing (see BIG RED tester manufactured by a German company M-Tronic in Fig. 2). Signals reflected from the ground or a signal transmitter placed on the ground are received by an ultrasonic receiver attached to the car wing and transferred to a microprocessor for further processing. The tester mounted on the vehicle wing measures body vibration damping by electronic means. Using a built-in microprocessor, the tester calculates data and displays results on a screen, which makes it far easier to analyse the vibrations as both the calculated numerical values and the curve of actual body vibrations are displayed.

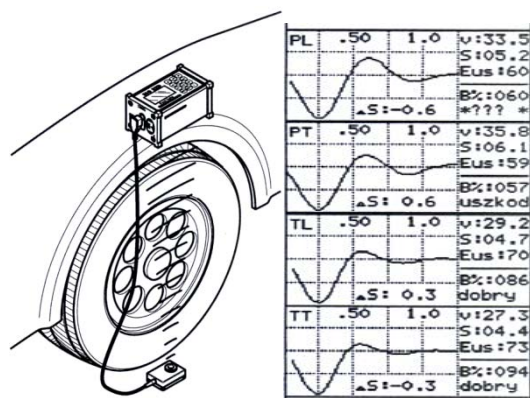

Fig. 2. BIG RED portable shock absorber tester and sample print-out of results [18]

Another method commonly used was the free vehicle fall which consisted in dropping a car from a specific height onto wheels. An oscillation sensor attached to the car body would record amplitudes of free vibrations. Consequently, one could obtain a graph illustrating the vibrations suppressed by the shock absorber. Having run with the car over an obstacle (as a result of the car body vibrations), one was able to determine if the shock absorber was operational.

The following drawings illustrate the pulse input function applied by dropping car wheels from a threshold (Fig. 3a) or by running over a rectangular bump (Fig. 3b).

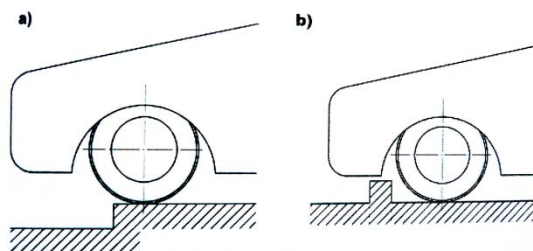

Fig. 3. Methods used to induce vibrations [6]

By application of the foregoing methods, technical condition of shock absorbers is generally assessed by comparing the number of recorded half-periods of car body vibrations with reference results defined for the given vehicle model. The free vibration method is characterised by low accuracy and the results it delivers are rather inaccurate and approximate. The vibration frequency one can obtain ranges between 0.7 and 1.5 Hz, and the assessment criteria applied to determine the condition of shock absorbers are the number of vibration half-periods and the rate at which they decay. The restricted range of frequencies tested is the reason why it is impossible to generate resonant vibrations caused by the effect of unsprung masses on the sprung ones, which matters greatly from the perspective of both comfort and stability of the vehicle motion, and consequently driving safety as well [12,13, 14, 15, 17].

## 2. SIMULATION TESTS

Simulation tests are used when new solutions are being designed, and they also make it possible to expand the knowledge in the field of technical condition diagnostics.

Frequencies of non-damped free vibrations observed in car bodies are assumed to range between 0.5 and 2.0 Hz for passenger cars and 3.0-5.0 Hz for race cars. For lower frequencies, the suspension system is softer, and it is characterised by increased grip, yet slower response. On higher frequencies, the total suspension system travel becomes limited. Free vibration frequencies of the car body typically differ between the front and the rear axle, which is due to various reasons, one of which being the necessity of taking changes in the static vehicle load (passengers and goods transported) into consideration.

In the study of automotive vehicles, selected dynamic phenomena observed during rectilinear motion, such as dynamic loading of suspension, powertrain and frame components, dynamic loading of road pavement and the impact exerted by vibrations on men can be investigated, or the technical condition of suspension system elements can be assessed by means of a simple two-mass quarter-vehicle model. In the model in question, as shown in Fig. 4, sprung masses  $m_1$  and unsprung masses  $m_2$  separate elastic element  $k_1$  (helical spring) from damping element  $c_1$  (shock absorber), whereas the unsprung mass is isolated from the kinematic input function induced by road profile  $h$  by the elastic-damping element of  $k_2$  and  $c_2$  (tyre) [1, 2, 3, 9, 11, 19, 20, 21, 22].

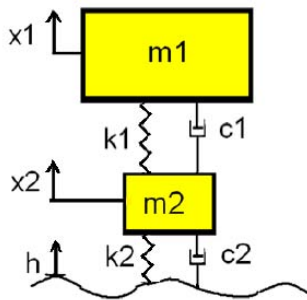

Fig. 4. Quarter-vehicle automotive suspension system model

With reference to the physical model depicted in Fig. 4, equations describing the motion of individual masses were determined by means of Lagrange's equations of the second kind.

$$m_1 \ddot{x}_1 + c_1(\dot{x}_1 - \dot{x}_2) + k_1(x_1 - x_2) = 0 \quad (1)$$

$$m_2 \ddot{x}_2 + c_1(\dot{x}_2 - \dot{x}_1) + c_2(\dot{x}_2 - \dot{h}) + k_1(x_2 - x_1) + k_2(x_2 - h) = 0 \quad (2)$$

The above system of differential equations was implemented in the Matlab/Simulink environment, thus creating a linear quarter-vehicle model. Both the characteristics of suspension system components, i.e. the spring and the shock absorber, and the tyre characteristics were described in the above model using linear functions. The model implemented in the Matlab/Simulink environment has been illustrated in Fig. 5.

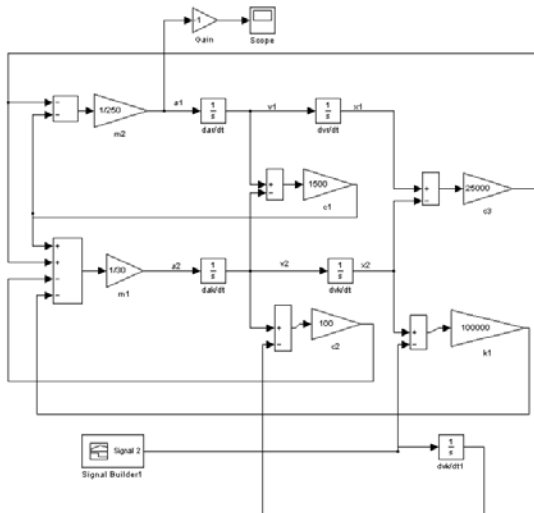

Fig. 5. Quarter-vehicle automotive suspension system model in Matlab/Simulink

The input function applied in the simulation tests (analogically to experimental tests conducted at the free vibration testing station) was induced by dropping car wheels from a threshold ( $h=0.1$  m). Contact with the foundation was intentionally moved in time ( $t=2.1$  s) against the drop ( $t=2$  s) in order to make the pre-set input function profile as realistic as possible.

The time curve of the input function signal has been shown in Fig. 6.

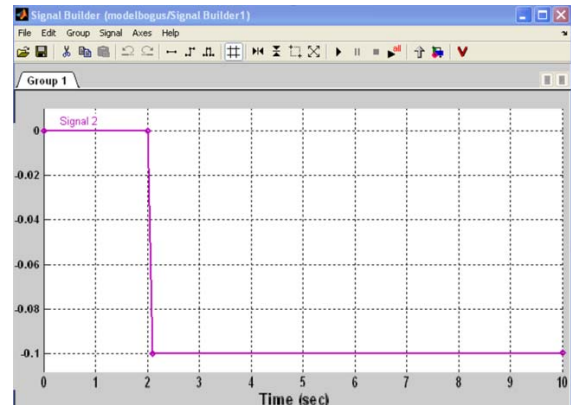

Fig. 6. Time curve of the input function signal induced by a drop from a threshold

Simulations were conducted by application of the fourth order Runge-Kutta method with a constant rate of 0.002 [s] corresponding to the sampling frequency of 500 [Hz] (equalling the frequency applied while recording vibration signals in experimental tests). Each simulation took 10 [s].

The studies involved a series of simulations conducted for a variable shock absorber ( $c_1$ ) parameter of attenuation constant. The results thus obtained have been illustrated in figures 7a and 7b.

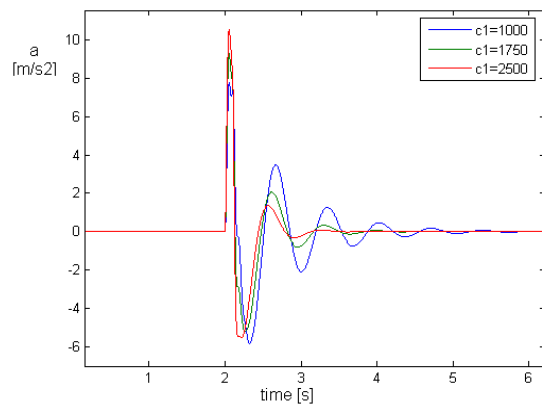

Fig. 7. Effect of the attenuation constant changes on time curves of vehicle body vibration accelerations – simulation tests

Having analysed the above curves, one may establish both qualitative and quantitative changes in the time curves of the analysed vibration acceleration signals recorded in the vehicle body as well as in differential accelerations. Differences in values of peak amplitudes as well as the number of oscillations are evident.

Despite the aforementioned major modelling simplifications (a linear damping model), one may find an explicit correlation between the shock absorber technical condition (described, in this case, by attenuation constant  $c_1$ ) and the system's response to a pulse input function, i.e. curves of

vibration accelerations established for individual elements of a passenger car.

### 3. EXPERIMENTAL TESTS

Fig. 8 shows the testing station used to induce free vibrations in the course of the studies in question [5, 6, 7, 8, 10, 19]. The height of the platform from which the vehicle was pushed was  $h=100$  mm.



Fig. 8. Effect of the attenuation constant changes on time curves of vehicle

In order to represent the change in the shock absorber technical condition, leakage of the shock absorbing liquid was simulated. The shock absorber used in the tests, was modified to allow for adjustment of the liquid level, has been shown in Fig. 9.



Fig. 9. Shock absorber filling

The experiment also included recording of vibration accelerations at selected points. Accelerometers were attached to the suspension arm (unsprung mass) and the car body (sprung mass), as shown in Fig. 10.

Capacitive acceleration converters by Analog Devices, ADXL 204 and ADXL 321, were used for the measurements. Another device used in the study was the K-lite analogue-digital card intended for cooperation with a PC via USB [4]. The unit enables measurements of electric parameters using an A/D converter measurement chain. A flowchart of the measurement chain has been provided in Fig. 11.



Fig. 10. Arrangement of vibration acceleration sensors



Fig. 11. Measurement chain flowchart

### 4. METHODOLOGY FOR ANALYSIS OF RESULTS

Test results were analysed in the Matlab environment. For that purpose, specific quantities (Fig. 12) were established to describe the suppressed free vibrations, namely logarithmic damping decrement, vibration period and relative damping coefficient.

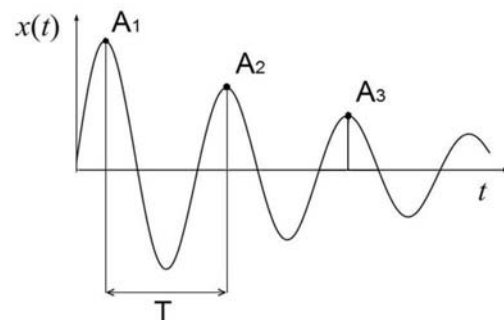

Fig. 12. Curve of suppressed free vibrations and points of analysis

Main parameters of the curve, i.e. period, frequency and logarithmic damping decrement (natural damping decrement logarithm), were determined as follows:

$$D = \ln \frac{A_n}{A_{n+1}} \quad (3)$$

where:

$A_n$  – amplitude of the  $n$ th vibration,

$A_{n+1}$  – amplitude of the next vibration.

For automotive shock absorbers, the logarithmic damping decrement equals  $D=1.3 \div 1.6$ , and the dependence between consecutive highest mass deflections is  $3.7 \div 4.5$ .

What was also determined was the relative damping coefficient (aperiodicity coefficient), calculated as follows:

$$\Psi = \frac{D}{\sqrt{4\pi^2 + D^2}} \quad (4)$$

In contemporary shock absorbers, the aperiodicity coefficient is  $\psi=0.25-0.50$ . [1]



5. ANALYSIS OF RESULTS

Fig. 13 provides a sample graph showing the breakdown into half-periods of the recorded vehicle body vibrations for the front suspension system of Fiat Punto.

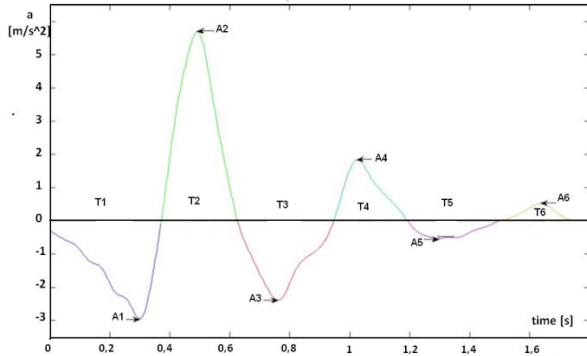

Fig. 13. Sample graph of free body vibrations in a breakdown into half-periods

For the curve of free vibrations, values of damping decrement  $D_i$  and of relative damping coefficient  $\Psi_i$  were calculated in accordance with the following dependences:

$$D_i = \ln \frac{A_i}{A_{i+2}} \tag{5}$$

$$\Psi_i = \frac{D_i}{\sqrt{4\pi^2 + D_i^2}} \tag{6}$$

The following figures illustrate the results of tests and analyses of Fiat Punto’s front suspension system.

Having analysed the results obtained by application of the free vibration method, one may conclude that in the event of a shock absorber defect in an automotive suspension system due to the shock absorbing liquid leakage, the method discussed in the paper may prove useful. Insofar as in the front suspension system one can identify monotonic changes in the function of technical condition, for the rear suspension system, interpretation of test results is a more complex problem.

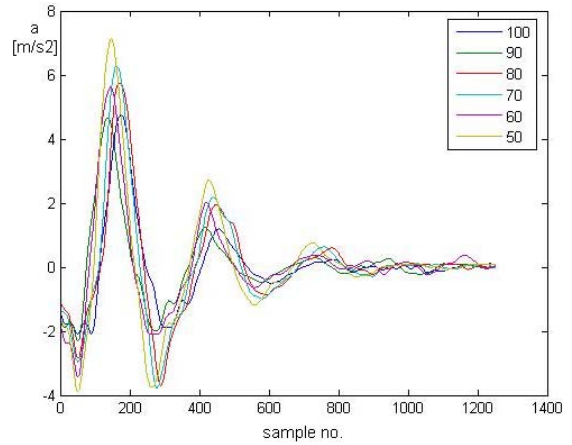

Fig. 14. Time characteristics of free vibrations for different shock absorbing liquid levels

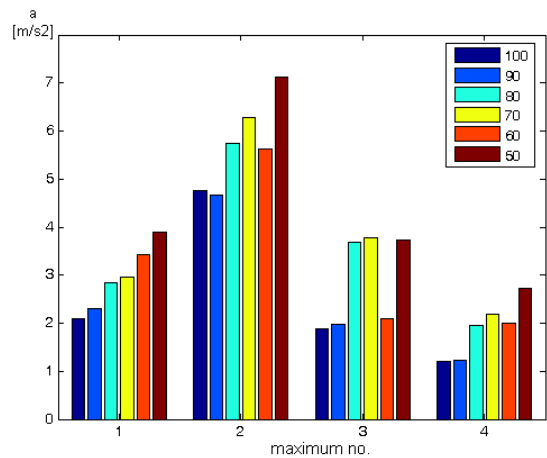

Fig. 15. Maximum amplitude values for individual half-periods

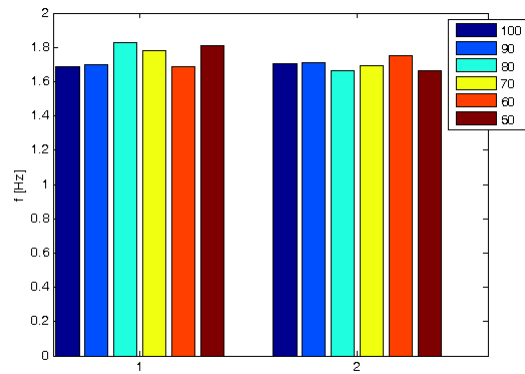

Fig. 16. Vibration frequency values calculated with reference to the former

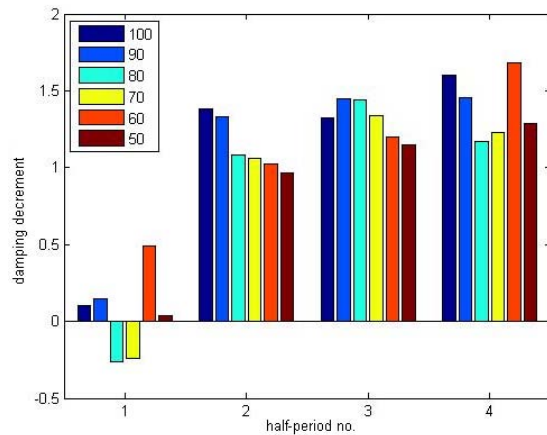

Fig. 17. Values of damping decrement

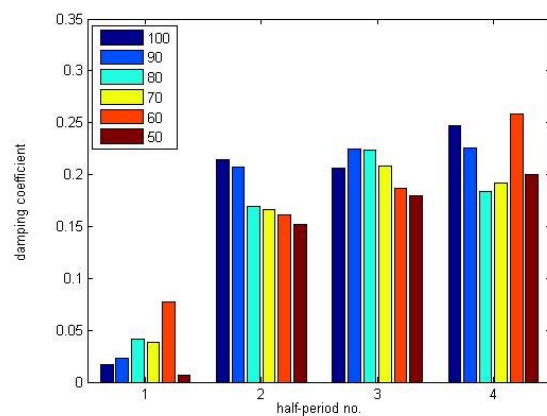

Fig. 18. Values of damping coefficients

## CONCLUSIONS

What proves to be most problematic about the pulse testing method is the repeatability of input function parameters and the utility of recording of acceleration values as vibration parameters. The free vibration method surely offers certain advantages (such as low costs and simplicity of signal analysis), however at present, it does not find practical application for purposes of technical condition assessment under conditions of vehicle inspection stations. To recapitulate on the foregoing, the free vibration method may be complementary towards the forced vibration method when applied to assess technical condition of suspension systems, yet such an approach is not common in practice.

## REFERENCES

1. Borkowski W, Konopka S, Prochowski L. The dynamics of working machines. Warszawa: WNT; 1996. Polish.
2. Dąbrowski Z, Pankiewicz J. Diagnosing a vehicle's suspension system on the basis of the non-linear effects of the dynamic response. *Machine Dynamics Problems* 2002; 26: 27-41.
3. Dixon JC. The shock absorber handbook. 2nd Edition, John Wiley & Sons, Inc., 2007.

4. Filipiak R, Jóska M. Research of the influence of air pressure in car tires on damping effectiveness of their suspension system. *Journal of Research and Application in Agriculture Engineering* 2009, Vol. 54(2), pp 42-47. Polish.
5. Gajek A, Juda Z. *Sensors*. Warszawa: WKiŁ; Warszawa; 2008. Polish.
6. Gardulski J. Methods of evaluation of the technical condition of the cars suspension without test stand. Radom ITE. 2003. Polish.
7. Gillespie TD. *Fundamentals of vehicle dynamics*. SAE International 1992.
8. Konieczny Ł, Burdzik R, Łazarz B. Application of the vibration test in the evaluation of the technical condition of shock absorbers built into the vehicle. *Vibroengineering. Journal of Vibroengineering*, 2013; 15(4):2068-2074.
9. Konieczny Ł, Burdzik R. Comparison of characteristics of the components used in mechanical and non-conventional automotive suspensions. Eds: J. Garus, P. Szymak. Stafa-Zurich, Trans Tech Publications, 2014, p. 26-31 (*Solid State Phenomena*; vol. 210 1012-0394).
10. Konieczny Ł. Analysis of simplifications applied in vibration damping modelling for a passive car shock absorber. *Shock and Vibration*. Volume 2016. DOI: <http://dx.doi.org/10.1155/2016/6182847>.
11. Konieczny Ł, Burdzik R. The influence of oil leak in vehicle shock absorber on its damping characteristics. *Diagnostyka*, 1(49)/2009: 83-86.
12. Konieczny Ł. Application of vibratory methods for assessment of technical condition of mechanical and hydropneumatic automotive suspension systems. Gliwice: Wydawnictwo Politechniki Śląskiej, 2015, Monografia 155. Polish.
13. Kupiec J, Słaski G. Influence of shock absorber damping force on tire force and results of tests made with use of suspension testers employing the resonance principle. *TRANSCOMP – International conference computer systems aided science, industry and transport. LOGISTYKA Dodatek Nauka*, 2009; 6:10. Polish.
14. Lozia Z. *Car diagnostics. Laboratory*. Warszawa: OWPW. 2007. Polish.
15. Reński A. *Car construction: Brake, steering and suspension systems*. Warszawa: OWPW. 2004. Polish.
16. Sitek K. New solutions of diagnostic line. *Auto Moto Serwis*, 24-27, 2009, 7-8.
17. Stańczyk TL, Jurecki R. Comparative analysis of testing methods of hydraulic shock absorbers. *Proceedings of the Institute of Vehicles*, 2014: 4(100):25–45.
18. Stańczyk TL. Analysis of the possibilities of using the phase angle as a diagnostic parameter in shock absorber examinations. *Archives of Transport*, 2004; 16(2): 33-50.
19. Trzeciak K. *Passenger car diagnostics*. Warszawa: WKiŁ. 2005. Polish.
20. Warczek J, Burdzik R, Konieczny Ł. Analysis of the forces generated in the shock absorber for conditions similar to the excitation caused by road roughness. *Dynamical systems: theoretical and experimental analysis*, Łódź, Poland, December 7-10, 2015. Ed. Jan Awrejcewicz. Berlin: Springer *Proceedings in Mathematics & Statistics*; 2016; 182: 373-383.
21. Warczek J, Broncel K. The application of determination method of dynamic properties of track

suspension in LabView. Scientific Journal of Silesian University of Technology. Series Transport, 2015; 86: 117-129.

22. Warczek J, Młyńczak J, Burdzik R, Konieczny Ł. Simulation of a visco-elastic damper based on the model of the vehicle shock absorber. Journal of Vibroengineering, 2015; 17(4): 2040-2048.

Received 2017-03-30

Accepted 2017-06-27

Available online 2017-08-10



**Lukasz KONIECZNY** is DSc PhD in Department of Automotive Vehicle Construction, Faculty of Transport, Silesian University of Technology. His research interests are: machinery vibrodiagnostic, digital analyse of signals, simulation researches of vehicle suspension dynamic, hydro-pneumatic suspensions.



**Jan WARCZEK** is Ph.D. researcher in Department of Vehicle Car Construction, Faculty of Transport Silesian University of Technology. Research interests: diagnostics and experimental simulation using vibroacoustics methods, dynamics of vehicle suspensions, method of active vibration reduction, nonlinear damping.



**Jakub MLYŃCZAK** is Ph.D. in Department of Transport Systems and Traffic Engineering, Faculty of Transport, Silesian University of Technology. His research interests are: railway technology, machinery diagnostic, switch point mechanism, railways turnouts, cooperation between switch point mechanism and railways turnouts, railways interlocking.



**Maciej ZAWISZA** received PhD degree in Faculty of Automotive and Construction Machinery Engineering from Warsaw University of Technology, Poland, in 2004. Now he works at the same place. His current research interests include dynamics of engines and vibroacoustic diagnostics of machines.