

THE EFFECTIVENESS OF MODAL BALANCING OF FLEXIBLE ROTORS

Janusz Zachwieja

UTP University of Science and Technology in Bydgoszcz, Faculty of Mechanical Engineering

Abstract

The rotors can be balanced using two different methods: a modal method and an influence coefficient method. Until recently, it was generally viewed that the former method can be used for balancing rigid rotors, whereas the latter method for balancing flexible rotors. Nowadays, the difference in classification of rotors and the approach to balancing have changed. The study presents general differences between the two balancing methods and compares the efficiency of balancing the flexible rotor using the modal method and the influence coefficient method.

Keywords: influence coefficient method, modal balancing, orthogonal functions

EFEKTYWNOŚĆ METODY MODALNEJ WYWAŻANIA WIRNIKÓW GIĘTKICH

Streszczenie

Wyważanie wirników przeprowadza się głównie dwoma metodami: modalną oraz macierzy współczynników wpływu. Istniało przekonanie, że pierwsza z wymienionych jest stosowana do wyważania wirników sztywnych, druga do wyważania wirników giętkich. Obecnie zatarciu uległa różnica w klasyfikacji wirników oraz zmienił się sposób podejścia do zagadnienia ich wyważania. W pracy przedstawiono zasadnicze różnice pomiędzy tymi dwoma sposobami wyważania oraz porównano efektywność wyważania wirnika giętkiego metodą modalną oraz metodą macierzy współczynników wpływu.

Słowa kluczowe: metoda macierzy współczynników wpływu, wyważanie modalne, funkcje ortogonalne

1. INTRODUCTION

The simplest balancing process is available for a statically unbalanced rigid rotor where the centre of mass and the axis of rotation do not coincide, whereas a dynamically unbalanced rigid rotor is a more complex case. The forces acting on the rotor can be reduced to a resultant vector and a resultant moment, and the balancing requires more than one, usually two correction planes.

A serious issue can be observed when balancing rotors which are subject to significant distortions in operation, in particular if the rotational speed approximate its critical speed.

Two different approaches to the flexible rotor balancing are available. The first approach, more commonly used, is based on the influence coefficient method which assumes causality between rotor unbalancing and its response to a constraint determined at any point, usually at the point of bearing. The modal balancing is of limited significance. The method assumes, that the shape of the unbalanced rotor axis approaches a specific form, characteristic for a specific critical speed. The modal balancing requires multiple rotor starting - one for each critical speed and the analysis of obtained data to select suitable correction weights and correction planes.

The flexible rotor balancing procedures are based on the modal characteristics of its response to the constraint. In this method, each modal form is compensated by a set of weights selected to avoid any interferences in the balancing effects for other forms. Two important assumptions are valid:

- (1) the damping in the system is low and negligible,
- (2) the forms are flat and orthogonal.

A balancing technique similar to the modal balancing has been first described by Grobel [1] and modified both theoretically and practically by Bishop [2] (Bishop, 1959), Bishop and Gladwell [3], and Bishop and Parkinson [4].

Other researchers, Saito and Azuma [5] and Meacham et al. [6] have published the studies on the modal method and have resolved several issues with balancing the rotors without an evident vibration form corresponding to the natural frequency as well as balancing rotors showing residual bending. The authors have also developed balancing procedures for higher vibration forms allowing for the effects of rotor weight. The methods have been presented and discussed by Darlow [7] The analytical methods are applied to determine the distribution of the correction weights in most cases of the modal balancing, although an in-depth knowledge of the dynamical model of the rotor is essential.

Numerous studies addressing the unbalance identification methods and other rotor imperfections as well as rigid and flexible rotor balancing have been developed in the recent years. The authors often try to convince us of the ingenuity of a specific method. In most cases, the procedures have the same disadvantage, which is a limited applicability in the industrial conditions.

Sudhakar and Sekhar [8] have suggested an unbalance identification method by reducing the function of the difference between the system response to an actual constraint and the load equivalent to a theoretical system model. The function arguments include parameters defining imperfection and an equivalent load value is determined based on a numerical model and measured vibration parameters. The imperfection models are created as the mathematical models of damage induced constraints. The method is based on a widely used method of damage symptom identification using numerical modelling [9].

The method presented by Khulief et al. [10] is based on standard high-speed flexible rotor balancing methods. As the authors explain, the method can be applied in balancing rotors in their own bearings. Its main advantage is that it does not require test weights and allows simultaneous balancing for several modal forms. It is crucial, since individual balancing of the rotor for one modal form affects the unbalance of a different modal form.

The balancing procedure should be accurate and, especially for machine rotors, should be quick and preferably automatic. Additional runs with the test weights take time, although since the quality factor achieved after one correction run depends on the test weight location, it can be changed by increasing the number of test runs, especially in cases where balancing is performed by reducing weight.

The method has been developed by Northwestern Polytechnical University team [11]. The test runs have been eliminated by numerical rotor modelling. Based on the experimental results for rotor with four disks, the deflection has been reduced by 80% after balancing at the first critical speed. Initial deflection reaching its maximum value of 0.12 mm at the first critical speed has been reduced to 0.06 mm .

Taplak et al. [12] have presented a simple rotor balancing method using an optimization theory based on a genetic algorithm. This solution can be of particular interest in determining the disk position of manual or automatic balancers [13].

A promising step in the direction of actual development of the balancing methods is a holospectrum method [14]. Traditional balancing methods are based on time curves recorded in one direction on up to two planes. The actual rotor movement is complex and must be defined by more

than a measurement of its parameters in a single direction or on a plane of one or even both bearings. The stiffness anisotropy, mostly of the rotor support but also of the shaft itself, requires the balancing process to be based on more accurate analysis of the nature of rotor vibrations, at least in orthogonal directions, which is part of the holospectrum method.

In his previous study, Liu [15] has described a course of flexible rotor balancing process, where the holospectrum is subject to decomposition into modal components. Rotor unbalance in the first two forms has been removed at rotor speed lower than its first critical speed.

2. EQUATIONS OF FLEXIBLE ROTOR MOTION

One of the criteria for classification of rotors into rigid and flexible is their critical speed [16]. The rotors with operating speed approximating or exceeding the critical speed are classified as flexible. Each rotor, to a lesser or greater extent, is subject to elastic deformation, and thus this criterion is highly inaccurate. Rieger [17] has defined five rotor categories, one of which includes flexible rotors.

The power turbine rotors are often analysed in this context [18][19] and it is recommended to determine the critical speed by measuring a static deflection of the rotor. (For rotors with critical speed of 3000 rpm , the deflection is approx. 0.1 mm). Due to self-aligning feature, the turbine rotors operate at speed higher than a first critical speed. It is recommended to assume the static deflection higher than 0.1 mm at the turbine rotor design stage.

The modal balancing is based on the concept of a deflection curve demodulation into its modal forms to balance the flexible rotor individually for each form.

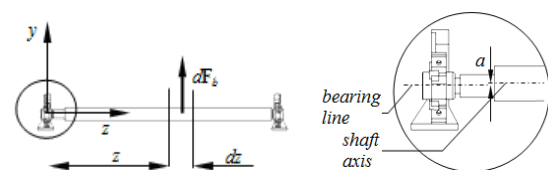

Fig. 1. Diagram of a modal balanced rotor

Fig. 1 shows a slim rotor supported by self-aligning bearings on both ends. The rotor unbalance results from non-symmetrical distribution of its weight in relation to its axis of rotation. The relative displacement of the shaft axis and the bearing line is determined as a . During its rotation around the z axis, the rotor is affected by an inertia force \mathbf{F}_b determined by rotor unbalance and rotational speed

$$\mathbf{F}_b = \int_0^L \rho A \omega^2 a(z) dz \quad (1)$$

Fig. 2 shows a non-inertial reference system rotating along with the analysed rotor. In relation to the system coordinates ξ and η , the equations of motion of the rotor component in a selected cross-section (determined by the position on the z axis) are defined as (2)

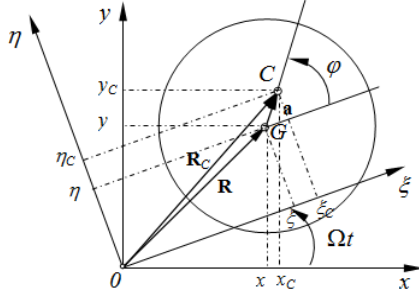

Fig. 2. Reference systems for rotor dynamics analysis

$$\begin{aligned} \rho A \ddot{\xi} + (C_i + C_e) \dot{\xi} - 2\rho A \Omega \dot{\eta} - \rho A \Omega^2 \xi - C_e \Omega \eta + \\ + EJ \frac{\partial^4 \xi}{\partial z^4} = \rho A a_{\xi} \Omega^2 \quad (2) \\ \rho A \ddot{\eta} + (C_i + C_e) \dot{\eta} + 2\rho A \Omega \dot{\xi} - \rho A \Omega^2 \eta + C_e \Omega \xi + \\ + EJ \frac{\partial^4 \eta}{\partial z^4} = \rho A a_{\eta} \Omega^2 \end{aligned}$$

Where ξ, η are the coordinates of the centre of cross-section of the rotor component, $\mathbf{a} = [a_{\xi} \ a_{\eta}]$ is a displacement vector of the rotor component's centre of mass in relation to its axis of rotation, Ω is an angular velocity, EJ is a flexural rigidity of the rotor's cross section, ρA is a unit weight, C_i, C_e are the coefficients of structural and external damping, z is a rotor component's coordinate on its axis.

By adding complex values:

$\zeta = \xi + i\eta$, $a = a_{\xi} + ia_{\eta}$ and defining the relation between damping, resonance vibration frequency and rotor weight as

$$C_i = 2\nu\omega\rho A, \quad C_e = 2\mu\omega\rho A \quad (3)$$

Where μ and ν are the damping coefficients, and ω is the resonance vibration frequency of the rotor. By multiplying the second equation by $i = \sqrt{-1}$ and adding to the first equation we have

$$\begin{aligned} \ddot{\zeta} + 2[\omega(\nu + \mu) + i\Omega]\dot{\zeta} - [\Omega^2 - 2\mu\omega i\Omega]\zeta + \\ + \frac{EJ}{\rho A} \frac{\partial^4 \zeta}{\partial z^4} = \Omega^2 a(z) \quad (4) \end{aligned}$$

Displacement of the centre of gravity $a(z)$ in relation to the axis of rotation can be defined as a series

$$a(z) = a_1\phi_1(z) + a_2\phi_2(z) + \dots = \sum_{j=1}^{\infty} a_j\phi_j(z) \quad (5)$$

where: $a_j = a_j^{Re} + ia_j^{Im}$, and $\phi_j(z)$ are the orthogonal functions satisfying the boundary conditions. A complex coordinate ζ can also be developed as a function of position and time into the following series

$$\begin{aligned} \zeta(z, t) = \psi_1(t)\phi_1(z) + \psi_2(t)\phi_2(z) + \dots = \\ = \sum_{j=1}^{\infty} \zeta_j(z, t) = \sum_{j=1}^{\infty} \psi_j(t)\phi_j(z) \quad (6) \end{aligned}$$

An expression ζ_j is a complex function

$$\zeta_j(z, t) = \zeta_j^{Re}(z, t) + i\zeta_j^{Im}(z, t) .$$

The natural vibrations of the rotor are defined as the relation (7)

$$\frac{EJ}{\rho A} \frac{\partial^4 \zeta}{\partial z^4} = -\frac{\partial^2 \zeta}{\partial t^2} \quad (7)$$

where: $\psi_j(t) = e^{i\omega_j t}$ and

$$\zeta(z, t) = \sum_{j=1}^{\infty} \phi_j(z) e^{i\omega_j t} \quad (8)$$

Therefore for each modal form, the following equations are satisfied

$$\frac{EJ}{\rho A} \frac{\partial^4 \phi_j(z)}{\partial z^4} e^{i\omega_j t} = \omega_j^2 \phi_j(z) e^{i\omega_j t} \quad (9)$$

$$\frac{EJ}{\rho A} \frac{\partial^4 \zeta_j}{\partial z^4} = \omega_j^2 \zeta_j \quad (10)$$

Allowing for the dependence (4) we obtain the equation of rotor motion for the j -th modal form as

$$\begin{aligned} \ddot{\zeta}_j + 2[\omega_j(\nu_j + \mu_j) + i\Omega]\dot{\zeta}_j + \\ - [\Omega^2 - 2\mu_j\omega_j i\Omega]\zeta_j + \omega_j^2 \zeta_j = \Omega^2 a_j \quad (11) \end{aligned}$$

If we omit the structural damping by assuming , the solution to the equation (11) is

$$\zeta_j = \frac{a_j \Omega^2}{\omega_j^2 - \Omega^2 + 2i\mu_j \omega_j \Omega}; \quad \varphi = \arctg \left(\frac{2\mu_j \omega_j \Omega}{\omega_j^2 - \Omega^2} \right) \quad (12)$$

Multiply the expression (5) by the function $\phi_k(z)$ and integrate from $0-L$

$$\int_0^L a(z) \phi_k(z) dz = \sum_{j=1}^{\infty} a_j \int_0^L \phi_j(z) \phi_k(z) dz \quad (13)$$

As results from the function orthogonality

$$\int_0^L \phi_j(z) \phi_k(z) dz = 0 \text{ for } j \neq k$$

$$\int_0^L \phi_j(z) \phi_k(z) dz = \int_0^L [\phi_j(z)]^2 dz = Z \text{ for } j = k \quad (14)$$

We can determine the subsequent coefficients in the series (5)

$$a_j = \frac{\int_0^L a(z) \phi_j(z) dz}{\int_0^L [\phi_j(z)]^2 dz} = \frac{1}{Z} \int_0^L a(z) \phi_j(z) dz \quad (15)$$

3. FLEXIBLE ROTOR BALANCING USING MODAL METHOD

Let us consider a symmetrical rotor (Fig. 1) supported on both ends by two bearings featuring a linear rigidity. The rigidity of the rotor itself is also linear and isotropic. The effect of damping and gyroscopic effect is negligibly small. A constant distribution of the unbalance along the rotor axis can be defined as

$$u_0(z) = \rho A(z) a(z) \quad (16)$$

Where ρ is a rotor material density, $A(z)$ is a cross-sectional area of the rotor as a function of its length, $a(z)$ is a function defining the distribution of eccentricity along the rotor axis without any deformations.

The unbalance, both constantly and discretely distributed in the N cross-sectional planes of the rotor can be defined as

$$u(z) = u_0(z) + \sum_{p=1}^N U_p \quad (17)$$

The equations defining the conditions of the modal balancing are as follows

$$R_A + R_B - \int_0^L u_0(z) dz - \sum_{p=1}^N U_p = 0,$$

$$R_B L - \int_0^L u_0(z) z dz - \sum_{p=1}^N U_p z_p = 0, \quad (18)$$

$$\int_0^L u_0(z) \phi_j(z) dz + \sum_{p=1}^N U_p \phi_j(z_p) = 0$$

If the rotor is balanced in relation to p_m modal forms, it requires correction in p_m+2 planes. Thus, the following conditions must be satisfied

$$\begin{bmatrix} 1 & 1 & \dots & 1 \\ z_1 & z_2 & \dots & z_{p_m+2} \\ \phi_1(z_1) & \phi_1(z_2) & \dots & \phi_1(z_{p_m+2}) \\ \phi_2(z_1) & \phi_2(z_2) & \dots & \phi_2(z_{p_m+2}) \\ \dots & \dots & \dots & \dots \\ \phi_{p_m}(z_1) & \phi_{p_m}(z_2) & \dots & \phi_{p_m}(z_{p_m+2}) \end{bmatrix} \begin{bmatrix} U_1 \\ U_2 \\ U_3 \\ U_4 \\ \dots \\ U_{p_m} \end{bmatrix} = \begin{bmatrix} \int_0^L u_0(z) dz \\ \int_0^L u_0(z) z dz \\ \int_0^L u_0(z) \phi_1(z) dz \\ \int_0^L u_0(z) \phi_2(z) dz \\ \dots \\ \int_0^L u_0(z) \phi_{p_m}(z) dz \end{bmatrix} \quad (19)$$

4. NUMERICAL EXAMPLE

The numerical example applies to the rotor model often used in industrial applications.

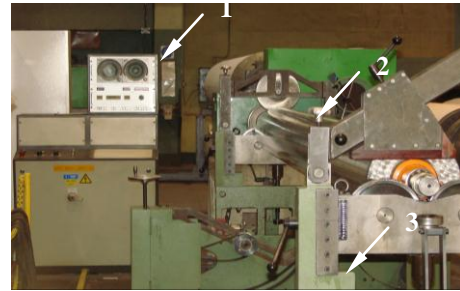
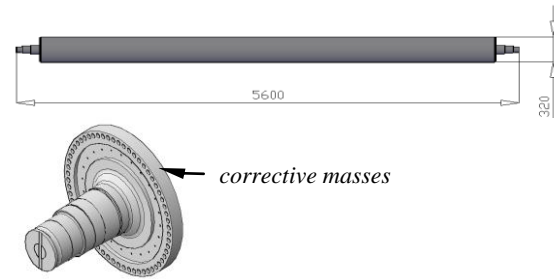

Fig. 3. Paper machine dryer rotor - Dimensions and balancing method: 1. - balancer measuring system, 2. shaft, 3. support.

Fig. 3. Paper machine dryer rotor mounted on stationary balancer supports. The shaft is balanced in two planes. The correction weights are attached to the holes drilled in the bottom. The main condition that must be met for the paper tape to achieve uniform thickness, and to prevent tearing is not only to eliminate vibrations in the bearing-shaft system but also to reduce strain corresponding to the shaft vibration form at critical speed (usually first critical speed). The balancing in two planes is not sufficient in this case. Thus, it is suggested to balance the shafts featuring high slenderness ratio, i.e. dryer rotors using modal balancing technique. In industrial applications, the change in balancing method must be preceded by a thorough analysis to determine its results. Thus, it is necessary to show the superiority of modal balancing technique over standard influence coefficient method in this specific case.

It is difficult to determine the distribution of an actual unbalance of the rotor. A numerical model presented in Fig. 4 is used in the analysis, where the unbalance is caused by the displacement parallel to the axis of rotor rotation in relation to the axis of symmetry by 1 mm. This unbalance state is specific to paper machine tubular shafts where the wall thickness is not uniform at the entire circumference or if the shaft neck and shell are misaligned.

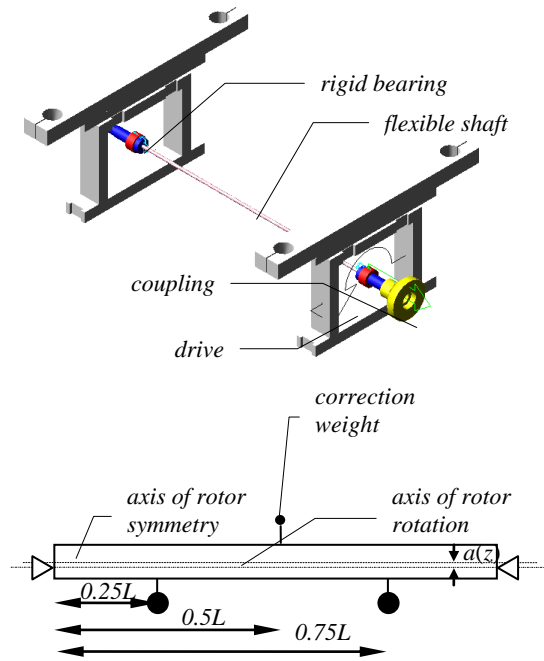

Fig. 4. Model for numerical analysis of rotor balancing

The rotor length is 800 mm and its weight is 0.378 kg. The rotor is supported by rigid bearings. Fig. 5 shows the critical speed and corresponding vibration forms up to a tertiary form. The weight eccentricity of 1 mm at uniform distribution along the rotor length results in the unbalance $U_p=0.378 \text{ kg} \cdot \text{mm}$.

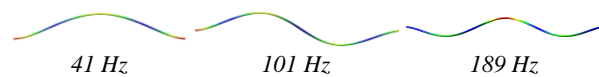

Fig. 5. The first three modal forms of the rotor model used in balancing simulation

Fig. 6 shows the path of the centre of rotor mass motion and the amplitude-frequency characteristics of the vibration speed. The balancing was performed at 35 Hz rotation frequency, below the critical frequency (41 Hz).

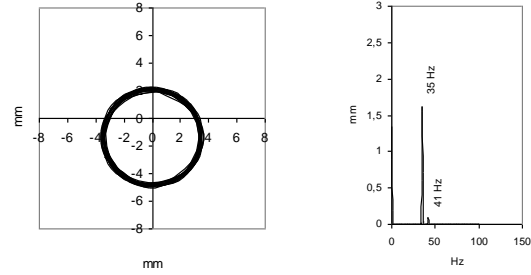

Fig. 6. Trajectory of movement and amplitude-frequency characteristic of the speed of vibration of the mass center of the rotor before balancing

The relation between the weight eccentricity and the unbalance is defined as the relation (16). The rotor balancing in its first modal form $p=1$ requires $k=p+2=3$ correction planes.

$$u_o(z) = \rho A(z) a(z) = \frac{\rho A(z) L}{L} a(z) = \frac{m}{L} a(z) \quad (20)$$

The first form of the natural vibrations of the rotor is defined as a function

$$\phi_1(z) = \sin \frac{\pi z}{L} \quad (21)$$

thus

$$\int_0^L u_0(z) dz = U, \int_0^L u_0(z) z dz = \frac{UL}{2}, \int_0^L u_0(z) \phi_1(z) dz = \frac{2U}{\pi} \quad (22)$$

The unbalance values based on equation (19) are $U_1=U_3=235 \text{ g} \cdot \text{mm}$ and $U_2=91.5 \text{ g} \cdot \text{mm}$. The correction weights added to the rotor in the distance of 10 mm from the axis of rotation for the rotor without any deformations are 23.5 g and 9.15 g. The weights must be distributed to achieve a zero total rotor unbalance.

The corrected weights used will determine the unbalance error

$$\begin{aligned} U_p - U_1 + U_2 - U_3 &= \\ &= 0.378 - 0.235 + 0.0915 - 0.235 = -0.0005 \text{ g} \cdot \text{mm} \end{aligned}$$

Fig. 7 shows the rotor condition after balancing, with the path of the centre of rotor mass motion and the spectrum of rotor vibration speed determined for its centre of mass.

The vibration amplitude values were reduced threefold as a result of modal balancing with modal function selected using the approximate boundary conditions. The correction weights were selected based on the equilibrium of forces acting on the rotor for the assumption that the modal function determining the unbalance distribution is correct for the articulated bearing. The bearing models used require boundary conditions with no displacement

and zero deflection angle in the bearing point. The reduction of natural rotor frequency to 38 Hz is the result of an increase in weight by 56.15 g corresponding to almost 15% of the rotor weight before balancing.

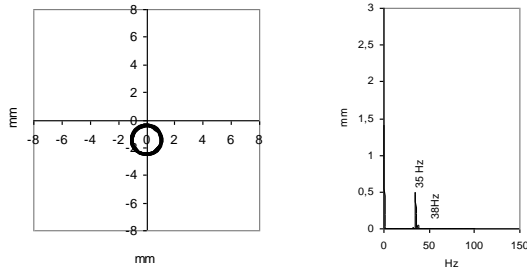

Fig. 7. Trajectory of movement and amplitude-frequency characteristic of the speed of vibration of the mass center of the rotor after balancing

A simulation of balancing using the influence coefficient method was carried out for comparison. It is a purely experimental phase method based on the assumption that the system's response to the constraint depends on this constraint's value. This relation can be described by the dependence (23)

$$\mathbf{N}_n = \mathbf{A}\mathbf{F}_n \quad (23)$$

Where \mathbf{N}_n is a rotor response vector, \mathbf{A} is an influence coefficient matrix and \mathbf{F}_n is an unbalance vector. The constraint vector correcting the unbalance can be defined as

$$\mathbf{F}_k = -\mathbf{F}_n = -\mathbf{A}^{-1}\mathbf{N}_n \quad (24)$$

provided that the influence coefficient matrix is known and is quadratic. If the influence coefficient matrix is not known, it must be determined by the analysis of the rotor response to a known constraint added to the rotor as a test weight. Its weight and position on the rotor are arbitrary, although wrong position and test weight will increase the rotor unbalance. This effect can be reduced by adding a correction weight.

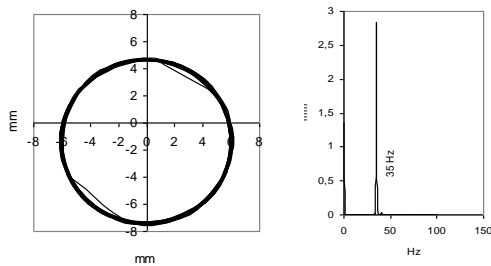

Fig. 8. Trajectory of movement and amplitude-frequency characteristic of the speed of vibration of the mass center of the rotor after attachment of the trial mass of 9.5 g

Fig. 8 shows an example. A 9.5 g test weight added to the rotor has increased the vibration amplitude of the centre of rotor mass five times. A single-plane balancing method was used where the correction plane was selected corresponding to a plane perpendicular to the rotor axis including its centre of mass. This approach is often used for balancing the paper machine cylinders.

The correction weight calculated with a formula (24) is 12.5 g . The test weight resulting in the increase in vibration amplitude must be removed and the correction weight must be added to the rotor in a point determined by the orientation of the vector \mathbf{F}_k in the reference system specific for the rotor. Fig. 9 shows the balancing effect.

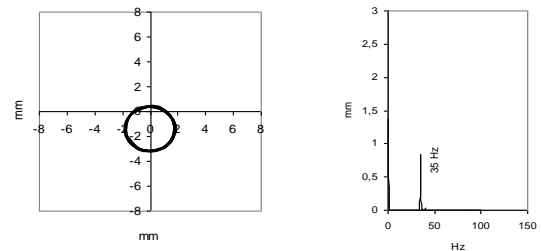

Fig. 9. Trajectory of movement and amplitude-frequency characteristic of the speed of vibration of the mass center of the rotor after balancing

Based on the comparison of the rotor vibration amplitudes after balancing using both methods, it can be assumed that the modal method yields a better dynamic state of the rotor. The influence coefficient method balancing was carried out for a single correction plane and a single balancing stage. In addition, it is also significant, that to achieve the effect showed in Fig. 9, it is sufficient to add a weight four times smaller than the weight used in the modal method.

Rotors with disks (power turbine and turbo generator rotors) can also be balanced using modal balancing technique. Fig. 10 shows turbo generator and its rotor. Machine rotor speed is almost $11,000\text{ rpm}$. At such speeds, deformation can significantly affect rotor durability.



Fig. 10. Turbo generator and high and low decompression stage rotors

Fig. 11 shows the efficiency of modal balancing of rotors with disk on the test stand. The unbalance model can be presented as a concentrated unbalance U_n at the middle of the rotor length. Balancing was performed at near first critical speed $p=1$. The number of correction planes was $n=p+2$. The correction planes were arranged symmetrically in the distance of $0.25L$, $0.5L$, $0.75L$, where L is the rotor length.

The rotor shown in Fig. 11 includes a shaft with $\varnothing 10$ mm diameter and weight as specified in the numerical example. The rotor is supported in ball bearings on both ends. A 1.2 kg disk, used as one of the correction planes is seated in the middle of the shaft. Rotor shaft deflection in a specific cross-section in orthogonal directions was measured with eddy current sensors fixed in the micrometre clamps.

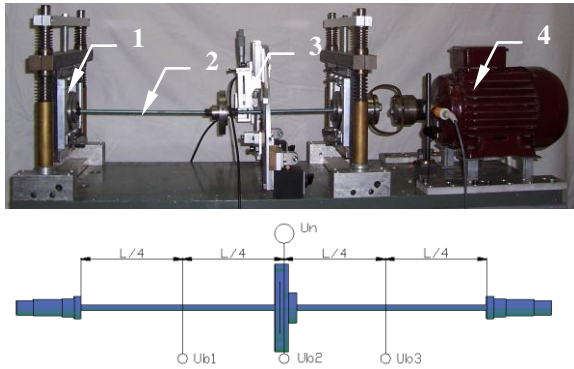

Fig. 11. Test stand and modal rotor unbalance model.

1. bearing base, 2. rotor, 3. support with micrometer screws and eddy current sensors, 4. motor

A 12.3 g weight was attached to the rotor disk, equivalent to ca. ~1% disk weight. The rotor was balanced at 22 Hz rotation frequency, below the critical frequency (23 Hz).

Fig. 3 shows a solid rotor. Non-solid rotor also features disks and in this case the location of its unbalance is difficult to determine, since the standard modal balancing techniques are non-phase methods.

Both unbalance value and location were known and determined to maintain the standard operating conditions using phase method, i.e. influence coefficient method. The quality factor of rotor balancing is a reference point to determine the efficiency of modal balancing technique.

The unbalance value was determined based on the change in rotor response to a known constraint. Rotor vibration parameters were measured at its support point. To eliminate the support stiffness anisotropy, a bearing displacement was measured in horizontal and vertical direction with a single correction plane. The size of the influence coefficient matrix was 4×1 . The correction vector

cannot be derived from the equation (24), which is replaced with

$$F_n = (A^*)^{-1} N_n \quad (25)$$

where A^* is the Moore–Penrose pseudoinverse matrix. The method is suggested by the author as a standard method for balancing rotors in their own bearings. Its superiority to standard two-plane balancing technique has been verified by balancing rotors with different imperfections. Determined unbalance $U_n = 492$ g·mm was corrected by attaching m_{b1} , m_{b2} , m_{b3} weights. The unbalance for the first modal form can be derived from

$$\phi_1^T (U_n + U_{b1} \phi_1) = 0 \quad (26)$$

Vector ϕ_1 and U_n are defined by

$$\phi_1^T = \left[\frac{\sqrt{2}}{2}, 1, \frac{\sqrt{2}}{2} \right], \quad U_n = [0, 492, 0] \text{ g} \cdot \text{mm} \quad (27)$$

The correction value is $U_{b1} = -246$ g·mm. Its distribution is defined by vector U_{b1}

$$U_{b1} = U_{b1} \phi_1 = [-174, -246, -174] \text{ g} \cdot \text{mm} \quad (28)$$

After attaching the weights to correct distribution (see equation 28) anticipated rotor unbalance was

$$U_c = \begin{bmatrix} 0 \\ 492 \\ 0 \end{bmatrix} + \begin{bmatrix} -174 \\ -246 \\ -174 \end{bmatrix} = \begin{bmatrix} -174 \\ 246 \\ -174 \end{bmatrix} \text{ g} \cdot \text{mm} \quad (29)$$

It indicates that the rotor is not balanced correctly as a rigid rotor and is balanced correctly as a flexible rotor at its first and second critical speed. For rotor to operate at third critical speed, it would be necessary to determine a new correction distribution.

$$\phi_3^T [U_c + U_{b3} \phi_3]; \quad U_{b3} = U_{b3} \phi_3 \quad (30)$$

Allowing for the balancing quality factor, shown in Fig. 11b and the fact that subsequent critical frequencies of 162 Hz and 218 Hz can be achieved, it can be assumed that the rotor is balanced correctly.

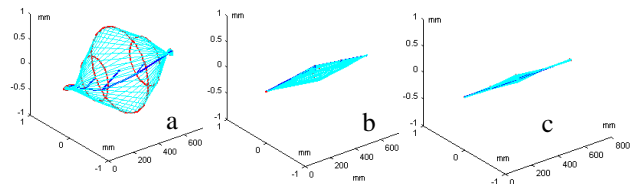

Fig. 12. Rotor holospectrum: a) before balancing, b) after balancing using influence coefficient method, c) after balancing using modal balancing technique

Comparison of the unbalance quality factor after balancing using the influence coefficient method (Fig. 12b) and modal balancing technique (Fig. 12c) shows that the values are similar. The difference in the amplitude of rotor vibration parameters at its point of support is negligibly small. Lower rotor deflection can be achieved by using the modal balancing technique, and in some cases, the difference is significant.

5. CONCLUSIONS

A conviction that the flexible rotors must be balanced using the modal method is no longer valid, since as shown in this study, the rotors can be successfully balanced using the influence coefficient method. The method is currently used for balancing standard flexible rotors such as the power turbine rotors. The turbine rotor balancing in its bearings was carried out using the influence coefficient method, whereas the modal balancing was usually carried out during overspeeding. Nowadays, even the turbine rotor balancing on a stationary balancing machine with isotropically supported bearings is carried out using the influence coefficient method.

There is a significant difference in rotor balancing speed between the modal method and the influence coefficient method. The former is performed at speeds approximate to the critical speed, whereas the near-resonance frequency range is not recommended for the latter method.

The influence coefficient method yields a higher quality factor, if the reduction of bearing vibrations is essential, in particular, it applies to the rigid rotors. The modal balancing aims to reduce the eccentricity of the rotor mass in relation to its axis of rotation. It is obvious, that in this case the centrifugal force, resulting from rotor unbalance, is reduced. A reduction in constraint is accompanied by a reduction in amplitude of dynamic response, although it is a secondary effect.

The modal balancing, although based on a solid theoretical base, is no match for the influence coefficient method, which is an experimental method allowing a better correlation between the constraint and the rotor response in a specific point of measurement.

Despite its drawbacks, the modal balancing is not completely superseded in the engineering practice and is in constant development. The new holospectrum based balancing method is the best example.

The ingenuity of the presented flexible rotor balancing method lays in combining the modal balancing technique and the influence coefficient method. The advantage of the solution has been observed by Drechsler [20] although the method is completely different. It uses fluctuation method to determine the influence coefficient matrix and the location of residual unbalance in rotor cross-

sections, at which the rotor vibration amplitudes in a wide range of rotor speeds are minimum. The author uses the specific features of the influence coefficient method, which as a phase method allows to pinpoint the actual location of rotor unbalance. It is clearly shown in the numerical example with known unbalance distribution, which usually is not the case in practice. Unbalance must be determined and the phase method is in this case very effective. The flexible rotor unbalance distribution is determined based on the measurement of bearing vibration parameters and their optimization in orthogonal directions by using the influence coefficient matrix as the Moore–Penrose pseudoinverse matrix.

REFERENCES

- [1] Grobel L. P., *Balancing turbine-generator rotors*, General Electric Review, 56(4), 22, 1953.
- [2] Bishop R.E.D., *The vibration of rotating shafts*, Journal of Mechanical Engineering Science, 1(1), 50, 1959.
- [3] Bishop R.E.D., Gladwell G.M.L., *The vibration and balancing of an unbalanced flexible rotor*, Journal of Mechanical Engineering Science, 1(1), 66, 1959.
- [4] Bishop R.E.D., Parkinson A. G., *On the use of balancing machines for flexible rotors*, ASME Transactions Journal of Engineering for Industry, 94, 561-576, 1972.
- [5] Saito S., Azuma T., *Balancing of flexible rotors by the complex modal method*, ASME Transactions Journal of Vibration, Acoustics, Stress, and Reliability in Design, 105, 94-100, 1983.
- [6] Meacham W.L., Talbert P.B., Nelson H.D., Cooperrider N.K., *Complex modal balancing of flexible rotors including residual bow*, Journal of Propulsion, 4, 245-251, 1988.
- [7] Darlow M.S., *Balancing of high-speed machinery*, Springer-Verlag, New York, 1989.
- [8] Sudhakar G.N.D.S, Sekhar A.S, *Identification of unbalance in a rotor bearing system*, Journal of Sound and Vibration, 330 (10), 2299–2313, 2011.
- [9] Zachwieja J., *The analysis of the rotor's longitudinal vibrations with large misalignment of shafts and ROTEX type coupling*, Diagnostyka - Diagnostics and Structural Health Monitoring, 58 (2), 19-23, 2011.
- [10] Khulief Y.A., Mohiuddin M.A., El-Gebeily M.: *A new method for field-balancing of high-speed flexible rotors without trial weights*, International Journal of Rotating , Article ID 603241, 11 pages, 2014.
- [11] Li X., Zheng L., Liu Z., *Balancing of flexible rotors without trial weights based on finite element modal analysis*, J. Vib. Control, 19 (3), 461–470, 2013.

- [12] Taplak H., Eekaya S, Uzmay I., *Passive balancing of a rotating mechanical system using genetic algorithm*, Scientia Iranica B, 19 (6), 1502–1510, 2012.
- [13] Zachwieja J., *Dynamic balancing of rotors with manual balancers*, Diagnostyka, 15 (4), 19-23, 2014
- [14] Liu S., Qu L., *A new field balancing method of rotor systems based on holospectrum and genetic algorithm*, Applied Soft Computing, 8 446–455, 2008.
- [15] Liu S., *A modified low-speed balancing method for flexible rotors based on holospectrum*, Mechanical Systems and Signal Processing, 21, 348–364, 2007.
- [16] Gryboś, R., *Drgania maszyn*. Wydawnictwo Politechniki Śląskiej, Gliwice, 2009.
- [17] Rieger, N., *Balancing of Rigid and Flexible Rotors*, Naval Research Laboratory, 1986.
- [18] Nikiel, T., *Turbiny parowe*, Wydawnictwa Naukowo-Techniczne, Warszawa, 1980.
- [19] Perycz, S., *Turbiny parowe i gazowe*, Zakład Narodowy im. Ossolińskich, Warszawa, 1992.
- [20] Drechsler J., *A combination of modal balancing and the influence coefficient method*, Proceedings of the Fourth World Congress on the Theory of Machines and Mechanisms, Newcastle, 1975.

Janusz ZACHWIEJA is the Professor in the Department of Applied Mechanics at the University of Science and Technology in Bydgoszcz (Poland). His scientific interests include dynamics of mechanical systems and fluid mechanics.

